

PH 型条形连接器 PH Bar Connector

间距 (space) : 2.0mm



技术参数 (SPECIFICATIONS)

适用线规 (Applicable wires) : AWG#28~AWG#22

温度范围 (Temperature range) : -25°C~85°C

额定电压 (Voltage rating) : 250V AC/DC

额定电流 (Current rating) : 2.5A

接触电阻 (Contact resistance) : $\leq 0.01 \Omega$

绝缘电阻 (Insulation resistance) : $\geq 1000M\Omega$

耐压 (Withstand voltage) : 800V AC/minute

认证 (STANDARDS) :  E200881

端子 TERMINAL

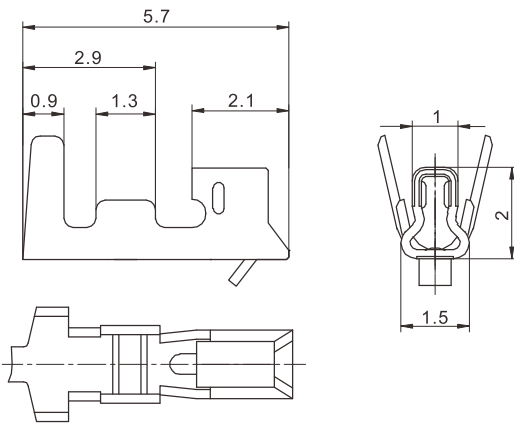

型号 Type	适用导线范围 Wire Range		导线外径 Wire ins.Dis
	mm ²	AWG#	
CH-PH	0.13 ~ 0.33	26 ~ 22	1.3 ~ 1.7
CH-PH-1	0.08	28	1.2
材质 · 表面处理 Material and Finish			
磷青铜 镀锡 Phos · bronze Tin · Plated			

阴连接器 HOUSING

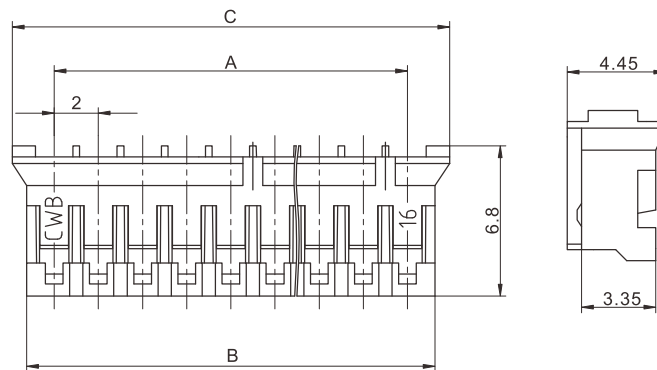

线数 Poles	型号 Type	尺寸 Dimensions (mm)			线数 Poles	型号 Type	尺寸 Dimensions (mm)		
		A	B	C			A	B	C
2	PH-2Y	2.0	4.5	5.8	10	PH-10Y	18.0	20.5	21.8
3	PH-3Y	4.0	6.5	7.8	11	PH-11Y	20.0	22.5	23.8
4	PH-4Y	6.0	8.5	9.8	12	PH-12Y	22.0	24.5	25.8
5	PH-5Y	8.0	10.5	11.8	13	PH-13Y	24.0	26.5	27.8
6	PH-6Y	10.0	12.5	13.8	14	PH-14Y	26.0	28.5	29.8
7	PH-7Y	12.0	14.5	15.8	15	PH-15Y	28.0	30.5	31.8
8	PH-8Y	14.0	16.5	17.8	16	PH-16Y	30.0	32.5	33.8
9	PH-9Y	16.0	18.5	19.8					
材质 · 表面处理 Material and Finish							PA66 UL94V-0		

PH 型条形连接器 PH Bar Connector

间距 (space) :2.0mm

阳连接器 HEADER (180°)

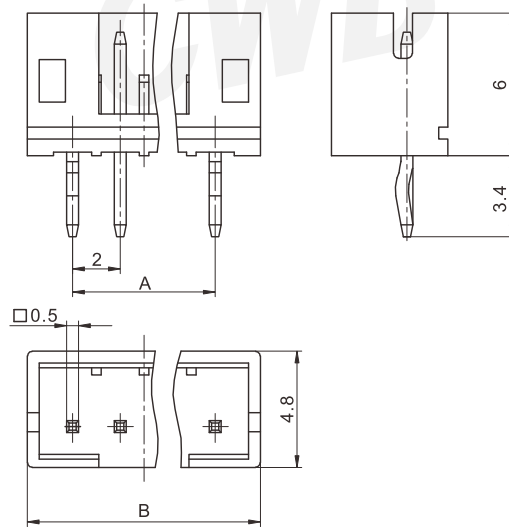

线数 Poles	型号 Type	尺寸 Dimensions (mm)		线数 Poles	型号 Type	尺寸 Dimensions (mm)	
		A	B			A	B
2	PH-2AK	/	6.0	9	PH-9AK	16.0	20.0
3	PH-3AK	4.0	8.0	10	PH-10AK	18.0	22.0
4	PH-4AK	6.0	10.0	11	PH-11AK	20.0	24.0
5	PH-5AK	8.0	12.0	12	PH-12AK	22.0	26.0
6	PH-6AK	10.0	14.0	14	PH-14AK	26.0	30.0
7	PH-7AK	12.0	16.0	15	PH-15AK	28.0	32.0
8	PH-8AK	14.0	18.0	16	PH-16AK	30.0	34.0

材质 · 表面处理 Material and Finish
PA66 UL94V-0; 黄铜 镀锡 Brass Tin · Plated

安装尺寸 MOUNTING MEASUREMENT

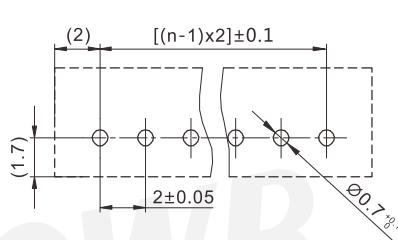

PCB Layout

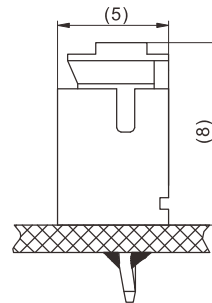

Assembly View (DIM FYI)

PH 型条形连接器 PH Bar Connector

间距 (space) :2.0mm

阳连接器 HEADER (90°)

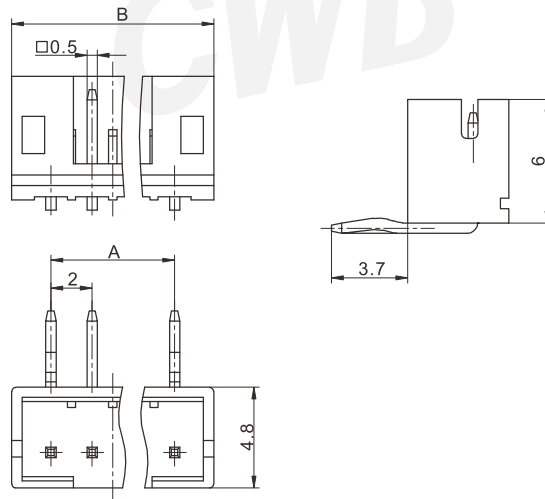

线数 Poles	型号 Type	尺寸 Dimensions (mm)		线数 Poles	型号 Type	尺寸 Dimensions (mm)	
		A	B			A	B
2	PH-2AWK	/	6.0	10	PH-10AWK	18.0	22.0
3	PH-3AWK	4.0	8.0	11	PH-11AWK	20.0	24.0
4	PH-4AWK	6.0	10.0	12	PH-12AWK	22.0	26.0
5	PH-5AWK	8.0	12.0	13	PH-13AWK	24.0	28.0
6	PH-6AWK	10.0	14.0	14	PH-14AWK	26.0	30.0
7	PH-7AWK	12.0	16.0	15	PH-15AWK	28.0	32.0
8	PH-8AWK	14.0	18.0	16	PH-16AWK	30.0	34.0
9	PH-9AWK	16.0	20.0				

材质 · 表面处理 Material and Finish
PA66 UL94V-0; 黄铜 镀锡 Brass Tin · Plated

安装尺寸 MOUNTING MEASUREMENT

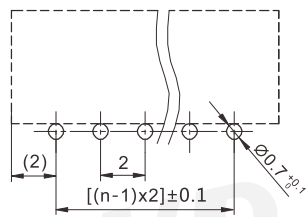

PCB Layout

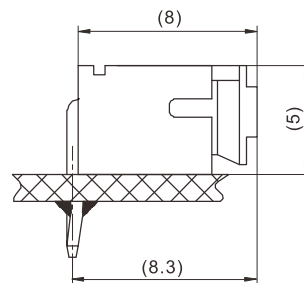

Assembly View (DIM FYI)

PH 型条形连接器 PH Bar Connector

间距 (space) :2.0mm

阳连接器 (带定位) HEADER (180°)

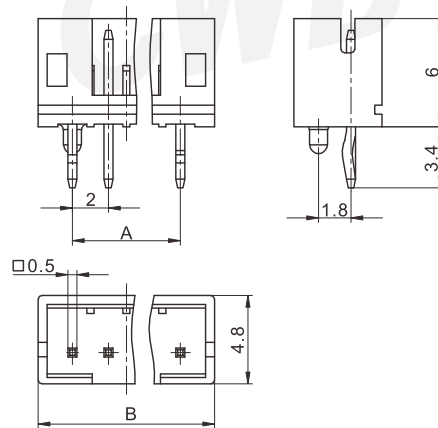

线数 Poles	型号 Type	尺寸 Dimensions (mm)		线数 Poles	型号 Type	尺寸 Dimensions (mm)	
		A	B			A	B
2	PH-2ADK	2.0	6.0	10	PH-10ADK	18.0	22.0
3	PH-3ADK	4.0	8.0	11	PH-11ADK	20.0	24.0
4	PH-4ADK	6.0	10.0	12	PH-12ADK	22.0	26.0
5	PH-5ADK	8.0	12.0	13	PH-13ADK	24.0	28.0
6	PH-6ADK	10.0	14.0	14	PH-14ADK	26.0	30.0
7	PH-7ADK	12.0	16.0	15	PH-15ADK	28.0	32.0
8	PH-8ADK	14.0	18.0	16	PH-16ADK	30.0	34.0
9	PH-9ADK	16.0	20.0				

材质 · 表面处理 Material and Finish
PA66 UL94V-0; 黄铜 镀锡 Brass Tin · Plated

安装尺寸 MOUNTING MEASUREMENT

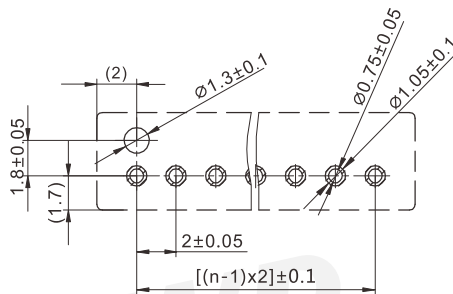

PCB Layout

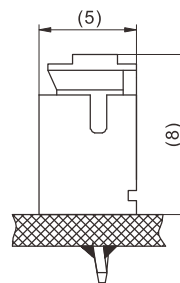

Assembly View (DIM FYI)

PH 型条形连接器 PH Bar Connector

间距 (space) :2.0mm

阳连接器 (带定位) HEADER (90°)

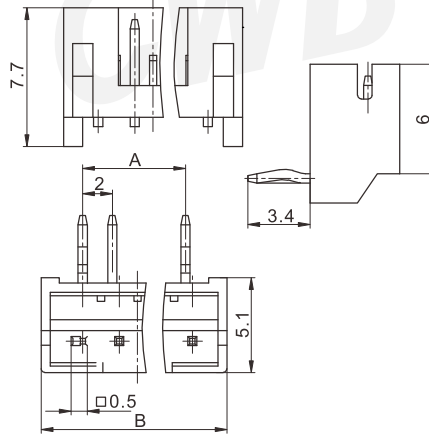

线数 Poles	型号 Type	尺寸 Dimensions (mm)		线数 Poles	型号 Type	尺寸 Dimensions (mm)	
		A	B			A	B
2	PH-2AWJK	/	6.0	10	PH-10AWJK	18.0	22.0
3	PH-3AWJK	4.0	8.0	11	PH-11AWJK	20.0	24.0
4	PH-4AWJK	6.0	10.0	12	PH-12AWJK	22.0	26.0
5	PH-5AWJK	8.0	12.0	13	PH-13AWJK	24.0	28.0
6	PH-6AWJK	10.0	14.0	14	PH-14AWJK	26.0	30.0
7	PH-7AWJK	12.0	16.0	15	PH-15AWJK	28.0	32.0
8	PH-8AWJK	14.0	18.0	16	PH-16AWJK	30.0	34.0
9	PH-9AWJK	16.0	20.0				

材质 · 表面处理 Material and Finish
PA66 UL94V-0; 黄铜 镀锡 Brass Tin · Plated

安装尺寸 MOUNTING MEASUREMENT

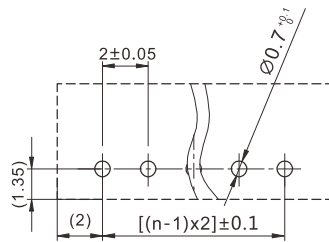

PCB Layout

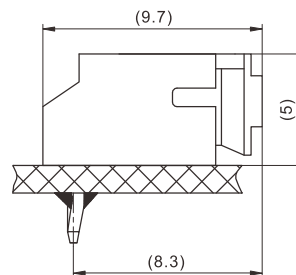

Assembly View (DIM FYI)

PH 型条形连接器 PH Bar Connector

间距 (space) :2.0mm

阳连接器 (塑件带定位) HEADER (90°)

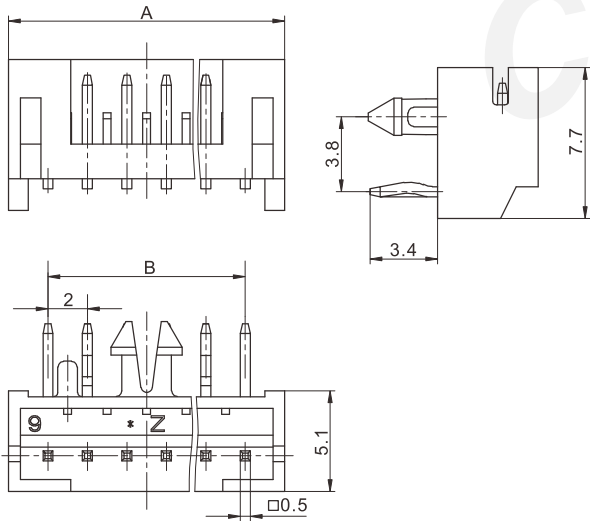

线数 Poles	型号 Type	尺寸 Dimensions (mm)	
		A	B
6	PH-6AWJDK	14.0	10.0
7	PH-7AWJDK	16.0	12.0
材质 · 表面处理 Material and Finish PA66 UL94V-0; 黄铜 镀锡 Brass Tin · Plated			

安装尺寸 MOUNTING MEASUREMENT

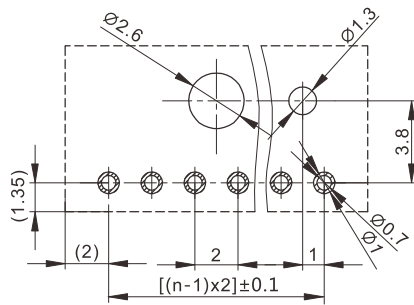

PCB Layout

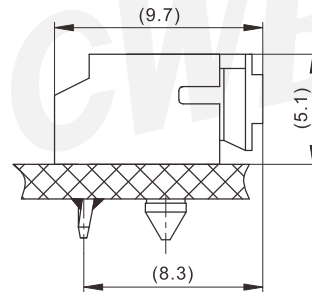

Assembly View (DIM FYI)

阳连接器 HEADER (180°) (SMT)

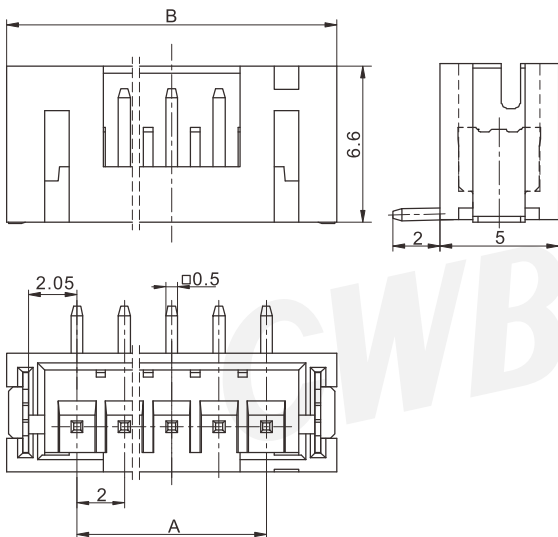

线数 Poles	型号 Type	尺寸 Dimensions (mm)		线数 Poles	型号 Type	尺寸 Dimensions (mm)	
		A	B			A	B
3	PH-3AB	4.0	10.0	10	PH-10AB	18.0	24.0
4	PH-4AB	6.0	12.0	11	PH-11AB	20.0	26.0
5	PH-5AB	8.0	14.0	12	PH-12AB	22.0	28.0
6	PH-6AB	10.0	16.0	13	PH-13AB	24.0	30.0
7	PH-7AB	12.0	18.0	14	PH-14AB	26.0	32.0
8	PH-8AB	14.0	20.0	15	PH-15AB	28.0	34.0
9	PH-9AB	16.0	22.0	16	PH-16AB	30.0	36.0
材质 · 表面处理 Material and Finish PA UL94V-0; 黄铜 镀锡 Brass Tin · Plated							

PH 型条形连接器 PH Bar Connector

间距 (space) :2.0mm

阳连接器 HEADER (90°) (SMT)

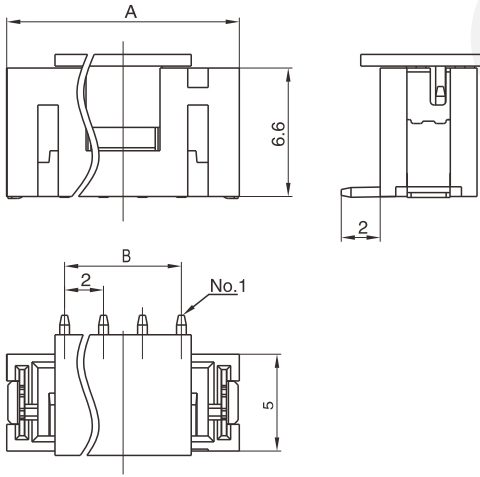

线数 Poles	型号 Type	尺寸 Dimensions (mm)	
		A	B
2	PH-2ABX1	8	2
3	PH-3ABX1	10	4
4	PH-4ABX1	12	6

材质 · 表面处理 Material and Finish
PA UL94V-0; 黄铜 镀锡 Brass Tin · Plated

阳连接器 (带吸嘴盖) HEADER (SMT)

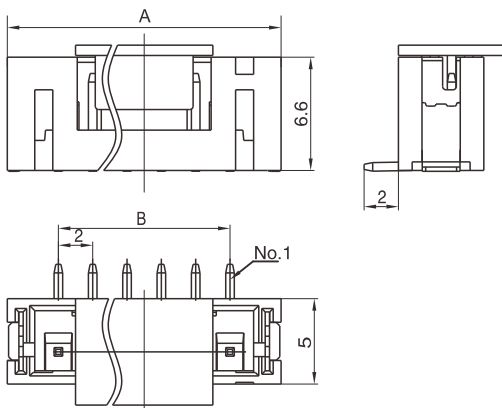

线数 Poles	型号 Type	尺寸 Dimensions (mm)	
		A	B
5	PH-5ABX2	14	8
6	PH-6ABX2	16	10
7	PH-7ABX2	18	12
8	PH-8ABX2	20	14
9	PH-9ABX2	22	16
10	PH-10ABX2	24	18
11	PH-11ABX2	26	20
12	PH-12ABX2	28	22
13	PH-13ABX2	30	24
14	PH-14ABX2	32	26
15	PH-15ABX2	34	28
16	PH-16ABX2	36	30

材质 · 表面处理 Material and Finish
PA UL94V-0; 黄铜 镀锡 Brass Tin · Plated

安装尺寸 MOUNTING MEASUREMENT

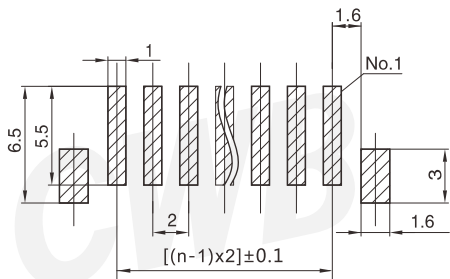

PCB Layout

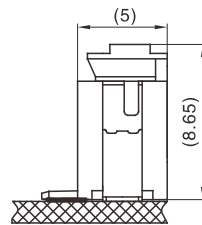

Assembly View (DIM FYI)

PH 型条形连接器 PH Bar Connector

间距 (space) :2.0mm

阳连接器 HEADER (90°) (SMT)

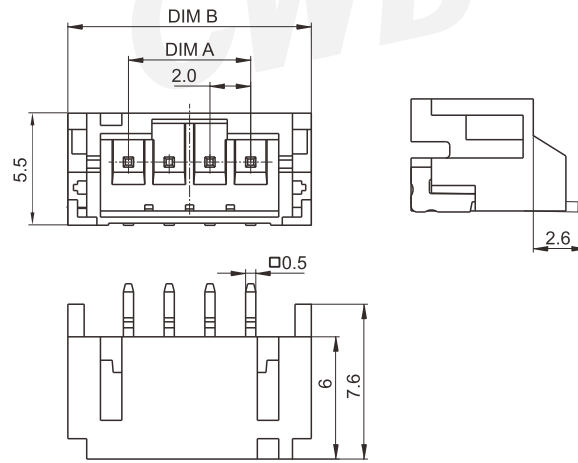

线数 Poles	型号 Type	尺寸 Dimensions (mm)		线数 Poles	型号 Type	尺寸 Dimensions (mm)	
		A	B			A	B
2	PH-2AWBJ	2.0	7.95	10	PH-10AWBJ	18.0	23.95
3	PH-3AWBJ	4.0	9.95	11	PH-11AWBJ	20.0	25.95
4	PH-4AWBJ	6.0	11.95	12	PH-12AWBJ	22.0	27.95
5	PH-5AWBJ	8.0	13.95	13	PH-13AWBJ	24.0	29.95
6	PH-6AWBJ	10.0	15.95	14	PH-14AWBJ	26.0	31.95
7	PH-7AWBJ	12.0	17.95	15	PH-15AWBJ	28.0	33.95
8	PH-8AWBJ	14.0	19.95	16	PH-16AWBJ	30.0	35.95
9	PH-9AWBJ	16.0	21.95				

材质 · 表面处理 Material and Finish
PA UL94V-0; 黄铜 镀锡 Brass Tin · Plated

安装尺寸 MOUNTING MEASUREMENT

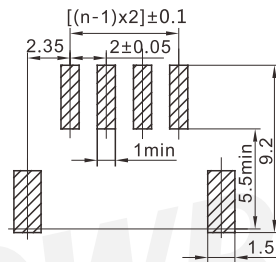

PCB Layout

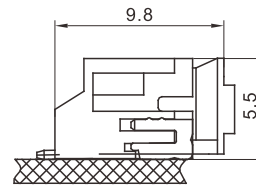

Assembly View (DIM FYI)